

Electrical Characteristics

($T_a = 25^\circ\text{C}$, $V_{cc} = +5\text{V}$)

Parameter	Symbol	Conditions	MIN.	TYP.	MAX	Unit
Dissipation current	I_{cc}	No input light	—	—	5.0	mA
High level output voltage	V_{OH}	*3	$V_{cc}-0.5$	-	-	v
Low level output voltage	V_{OL}		-	-	0.45	v
High level pulse width	T_1		400	-	800	μs
Low level pulse width	T_2		400	-	800	
B.P.F. center frequency	f_0	-	-	*40	-	kHz

*3 The burst wave as shown in the following figure shall be transmitted by the transmitter shown in Fig. 1.

*4 Diversified models with a different B.P.F frequency, as shown in a separate table, are also available.

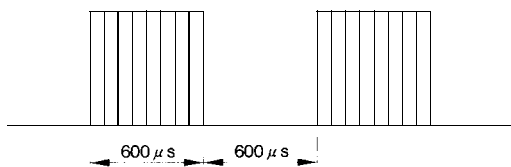

The value of f_0 is shown in a separate table.
Duty 50%

Model Line-up

Model No.	B.P.F. frequency	Unit
GP1 U58X	40	kHz
GP1U580X	36	
GP1U581X	38	
GP1U582X	36.7	
GP1U583X	32.75	
*	41.7	
*	48	
GP1U587X	56.8	
*	39	
*	35	

* Also available on request

Internal Block Diagram

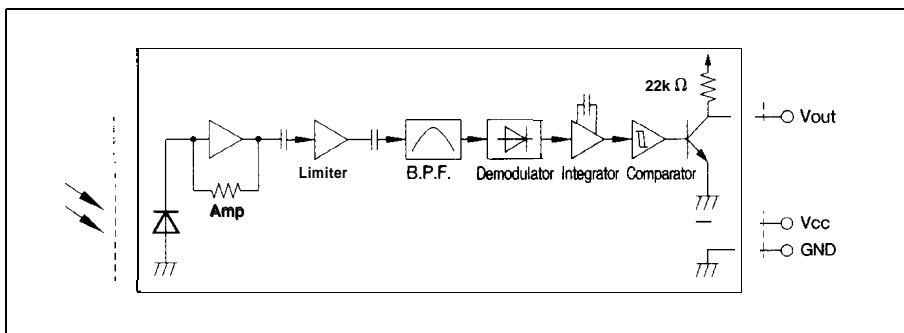

Units

IR D

10

■ Performance

Using the transmitter shown in Fig. 1, the output signal of the light detecting unit is good enough to meet the following items in the standard optical system in Fig. 2.

(1) Linear reception distance characteristics

When $L = 0.2$ to 8m , $E_e < 10\text{ lx}$ and $\phi = 0^\circ$ in Fig. 2, the output signal shall meet the electrical characteristics in the attached list.

(2) Sensitivity angle reception distance characteristics

When $L = 0.2$ to 6m , $E_e < 10\text{ lx}$ and $\phi \leq 30^\circ$ in Fig. 2, the output signal shall meet the electrical characteristics in the attached list.

(3) Anti outer peripheral light reception distance characteristics

When $L = 0.2$ to 4m , $E_e \leq 300\text{ lx}$ and $\phi = 0^\circ$ in Fig. 2, the output signal shall meet the electrical characteristics in the attached list.

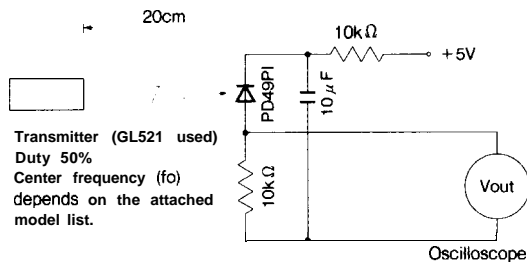

Fig. 1. **Transmitter**

In the above figure, the transmitter should be set so that the output V_{out} can be 40mV_{PP} . However, the PD49PI to be used here should be of the short-circuit current $I_{sc} = 2.6\ \mu\text{A}$ at $E_v = 100\text{ lx}$.

(E_v is an illuminance by CIE standard light source A (tungsten lamp).)

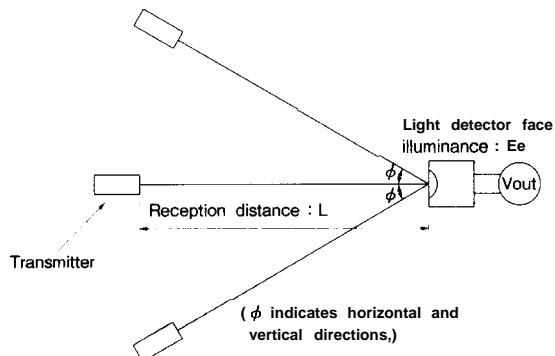

Fig. 2. standard **optical system**

■ Precaution for Use

- (1) Use the light emitting unit (remote control transmitter), in consideration of performance, characteristics and operating condition of light emitting device and the characteristics of the light detecting unit.
- (2) Pay attention to a malfunction of the light detecting unit when the surface is stained with dust and refuse. Care must be taken not to touch the light detector surface. If it should be dirty, wipe off with soft cloth so as to prevent scratch. In case some solvents are required, use methyl alcohol, ethyl alcohol or isopropyl alcohol. Also, protect the light detecting unit against flux and others.
- (3) The shield case shall be grounded on PWB pattern.
- (4) Do not apply unnecessary force to the terminals and case from outside.
- (5) Do not push the light detector surface (photodiode) from outside.
- (6) To avoid the electrostatic breakdown of IC, handle the unit under the condition of grounding with human body, soldering iron, etc.
- (7) In case of adopting the infrared light detecting unit for the wireless remote control, use it in accordance with the transmission scheme and the signal format recommended in “Countermeasures for malfunction prevention of home appliances with infrared remote control” issued from Japan Association of Electrical Home Appliances (AEHA) in July 1987.
- (8) As for other general cautions, refer to the chapter “Precautions for Use” (Page 78 to 93).